

ISOMETRIC VIEW

SEE NOTE 1

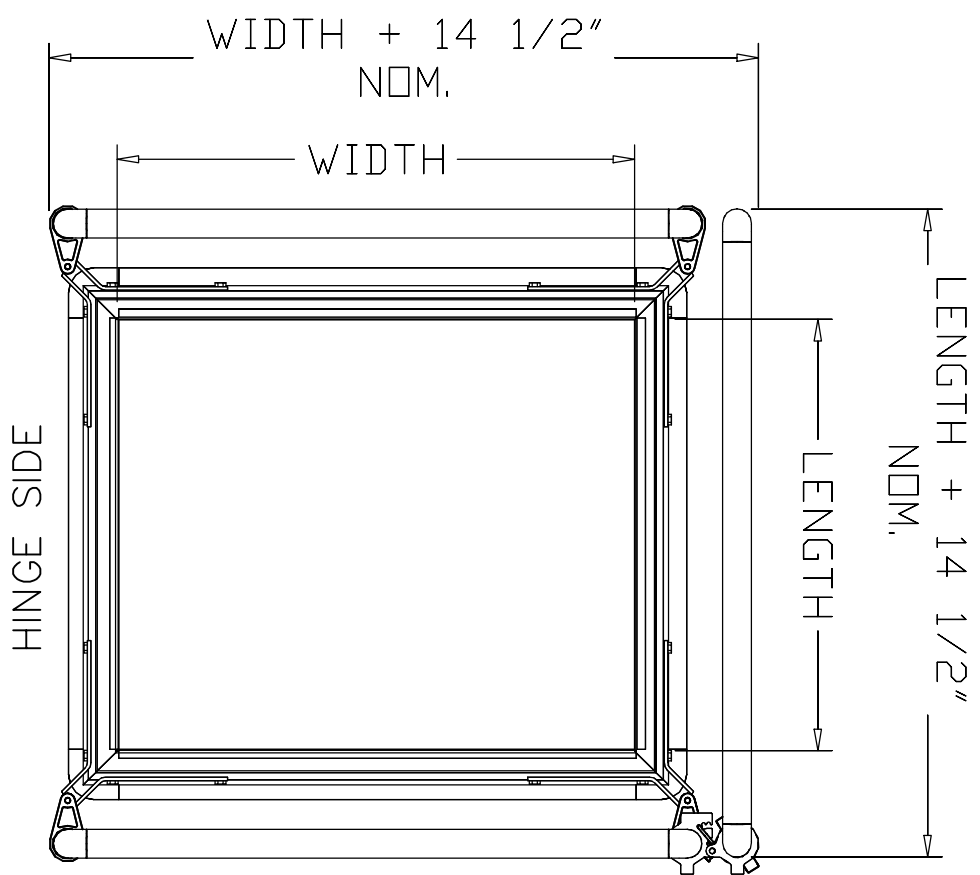

PLAN VIEW
SHOWN WITHOUT COVER

SPECIFICATIONS

1. Fiberglass reinforced polymer (FRP), yellow, uv resistant & fire retardant (Ø1.91)
2. Self closing (FRP) gate (Ø1.91)
3. Aluminum post supports
4. Steel corner brackets (hot dip galvanized)
5. Aluminum gate hinge
6. Aluminum post hinge
7. Stainless steel torsion rod

NOTES:

1. TOP OF RAIL TO BE SET 42" ABOVE THE ROOF SURFACE OR DECK
2. STANDARD LEFT HAND GATE SHOWN
3. ALL FASTENERS STAINLESS STEEL
4. ALL PARTS AND FASTENERS ARE INCLUDED IN PACKAGE. CAPFLASHING MUST BE STRUCTURALLY SOUND TO SUPPORT ASSEMBLY.

Customer:

P.O. N°

Job:

Contractor:

Architect:

Engineer:

Sales Rep:

Manufacturers of Doors for Special Services
Bilco® THE BILCO COMPANY
 New Haven, Connecticut 06505

**BIL-GUARD®
HATCH RAIL SYSTEM**

QTY	TYPE	SIZES	
		W	L
<input type="checkbox"/>	RL-S	3'-0"	x 2'-6"
<input type="checkbox"/>	RL-E	3'-0"	x 3'-0"
<input type="checkbox"/>	RL-F	4'-0"	x 4'-0"

THIS DRAWING IS THE PROPERTY OF THE BILCO COMPANY AND INCORPORATES INFORMATION WHICH IS PROPRIETARY. PUBLICATION AND/OR PUBLIC DISTRIBUTION IN WHOLE OR IN PART IS EXPRESSLY PROHIBITED WITHOUT THE PRIOR WRITTEN CONSENT OF THE BILCO COMPANY. THE INFORMATION CONTAINED HEREIN REMAINS THE PROPERTY OF THE BILCO COMPANY. ALL RIGHTS RESERVED.